

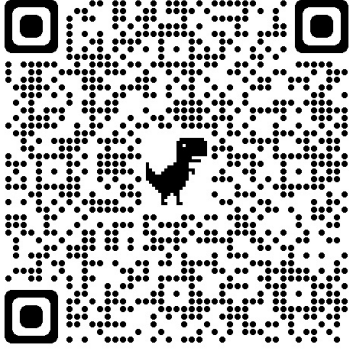

| | | | | | | | | | | | | | | | | | | |
|---|---|---|--|---|---|---|---|---|---|----|---|----|---|----|----|----|---|----|
| | 1 | 2 | 3 | 4 | 5 | 6 | 7 | 8 | 9 | 10 | 11 | 12 | 13 | 14 | 15 | 16 | 17 | 18 |
| A |  | | <h1>Breeze</h1> <h2>ENERGY STORAGE SYSTEM</h2> | | | | | | | | | |  | | | | | |
| B | | | | | | | | | | | | | | | | | | |
| C | ANDROID APP | | DOKUMENTACJA TECHNICZNA | | | | | | | | | | APPLE APP | | | | | |
| D | | | | | | | | | | | | | | | | | | |
| E | POJEMNOŚĆ MAGAZYNU: 10 kWh | | | | | | | | | | | | | | | | | |
| F | Falownik DEYE SUN-12K-SG04LP3-EU | | | | | | | | | | | | | | | | | |
| G | SN: | | | | | | | | | | | | | | | | | |
| H | Data Logger: | | | | | | | | | | | | | | | | | |
| | SN: | | | | | | | | | | | | | | | | | |
| | PWD: | | | | | | | | | | | | | | | | | |
| | | | | | | | | | | |  | | | | | | | |
| | | | | | | | | | | |  | | AKUMULATORY ION BREEZE 4850 | | | |  | |
| | | | | | | | | | | | Instrukcja | | | | | | Specyfikacja | |

| | | | |
|----------------------------|------------------------------------|--|--------------|
| Breeze | Bartosz Chorowiec: E1/712/17258/22 | 2023/08/002/Z/S | dokumentacja |
| | Maciej Wieczorek: D/681/1221/2020 | | techniczna |
| Breeze Energies Sp. z o.o. | Date: 19/01/2024 | ul. Kolejowa 44 05-092 Łomianki POLAND | Folio: 1/6 |

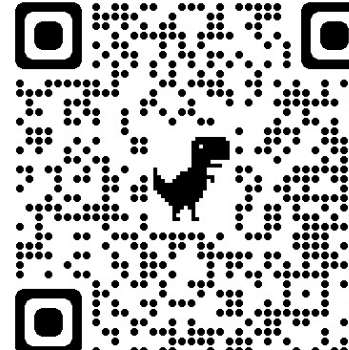

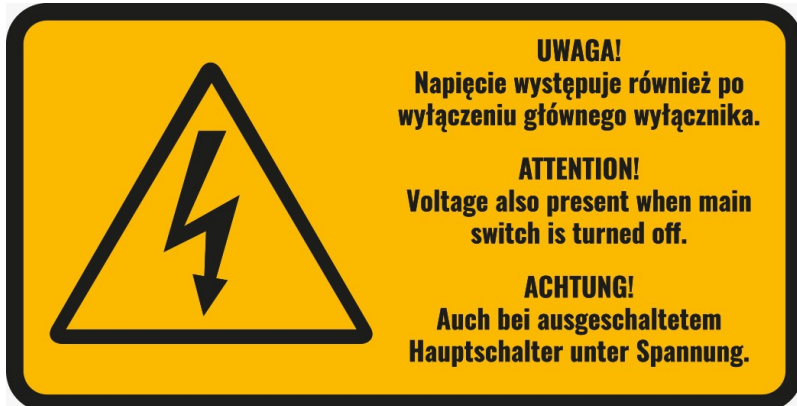

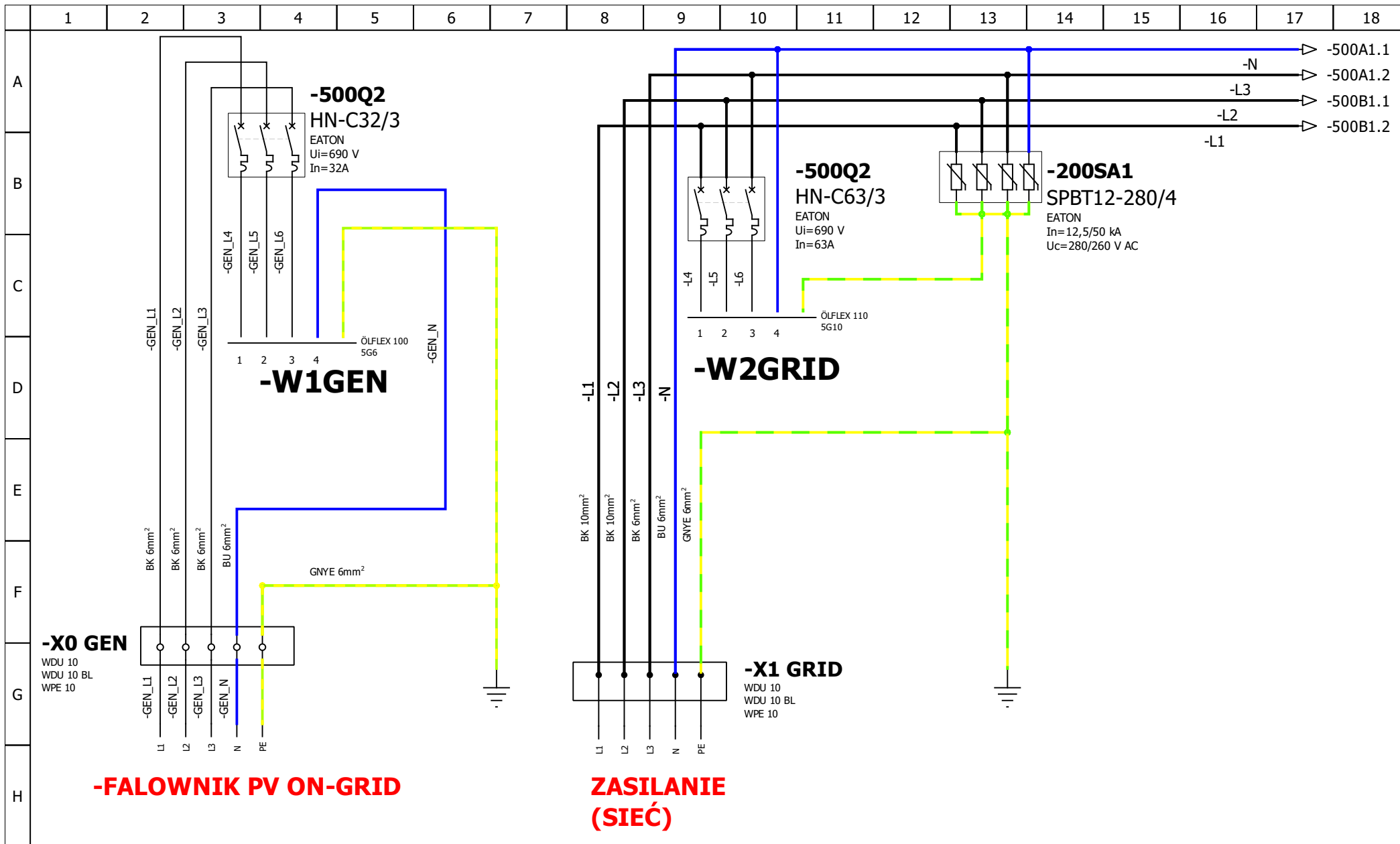
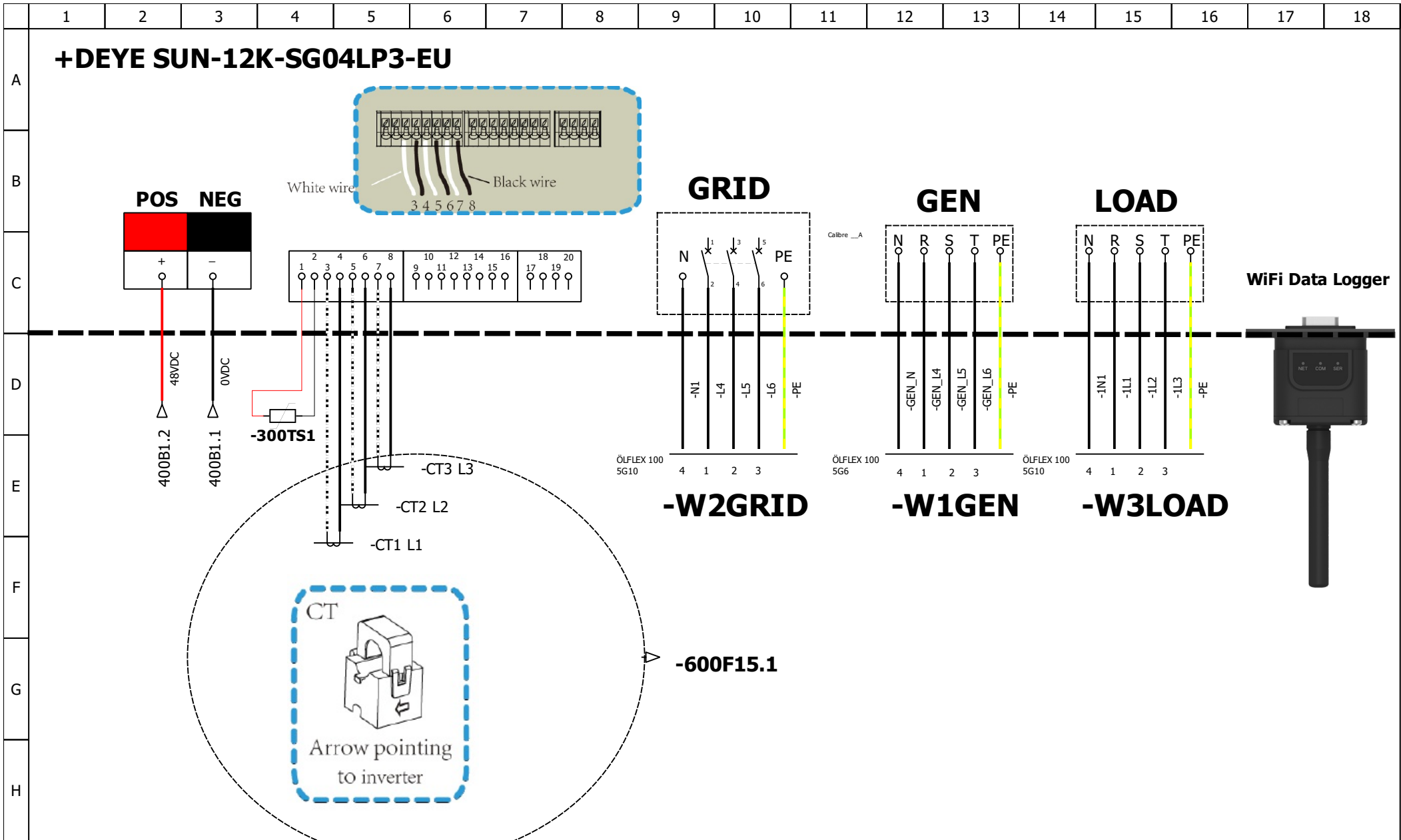
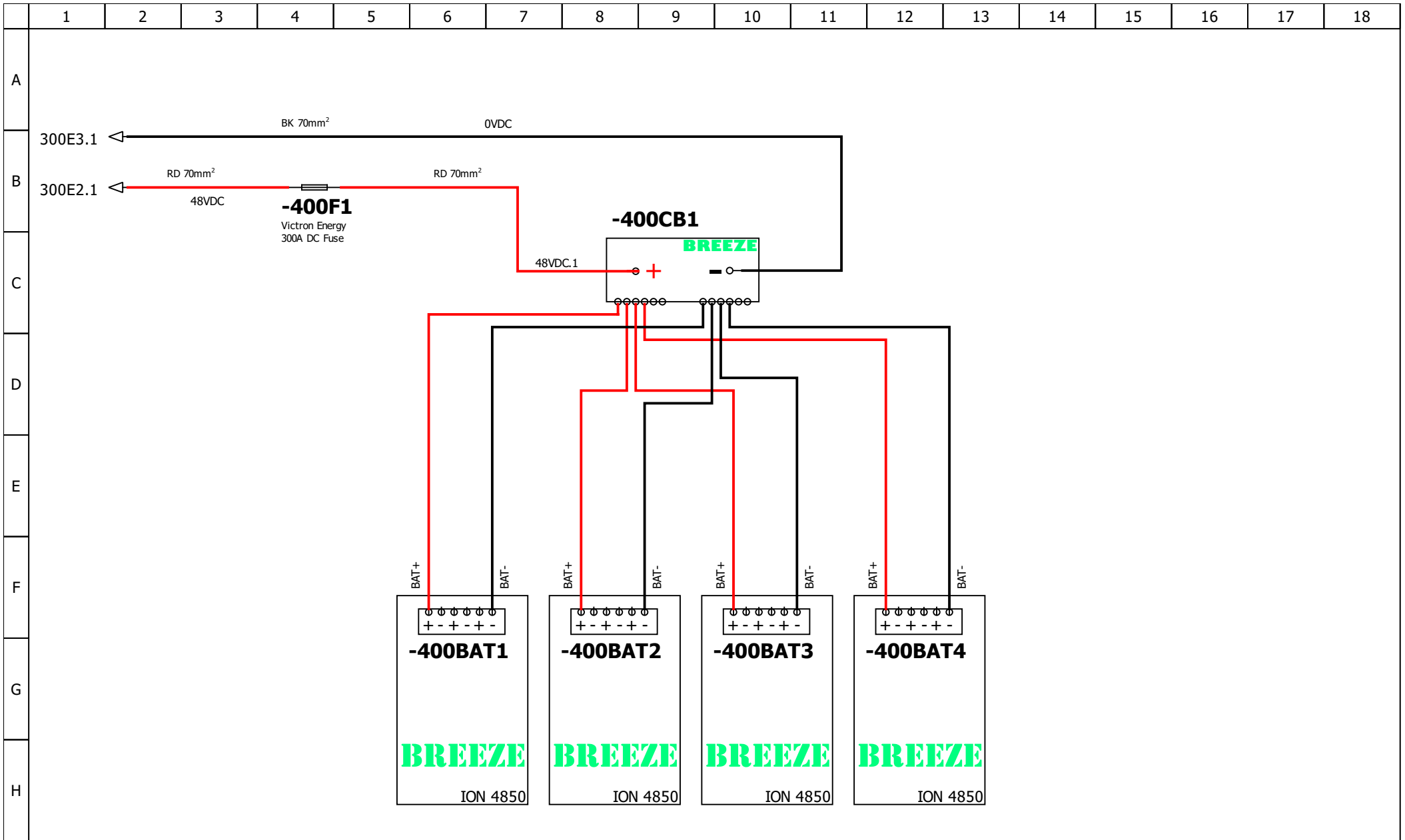

Bartosz Chorowiec: E1/712/17258/22

Maciej Wieczorek: D/681/1221/2020

Date: 19/01/2024

2023/08/002/Z/S

ul. Kolejowa 44 05-092 Łomianki POLAND

dokumentacja

techniczna

Breeze Energies Sp. z o.o.

Folio: 4/6

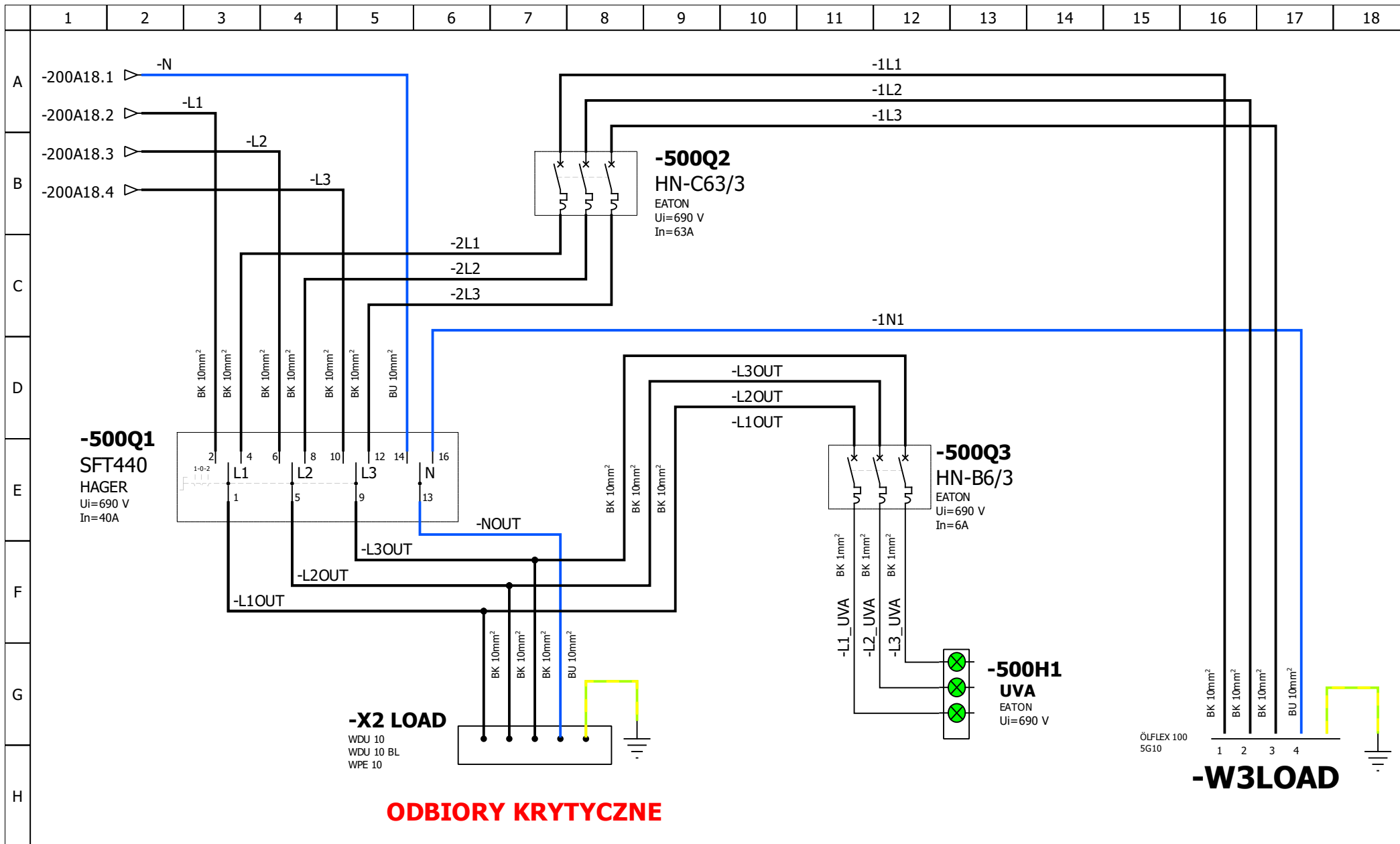

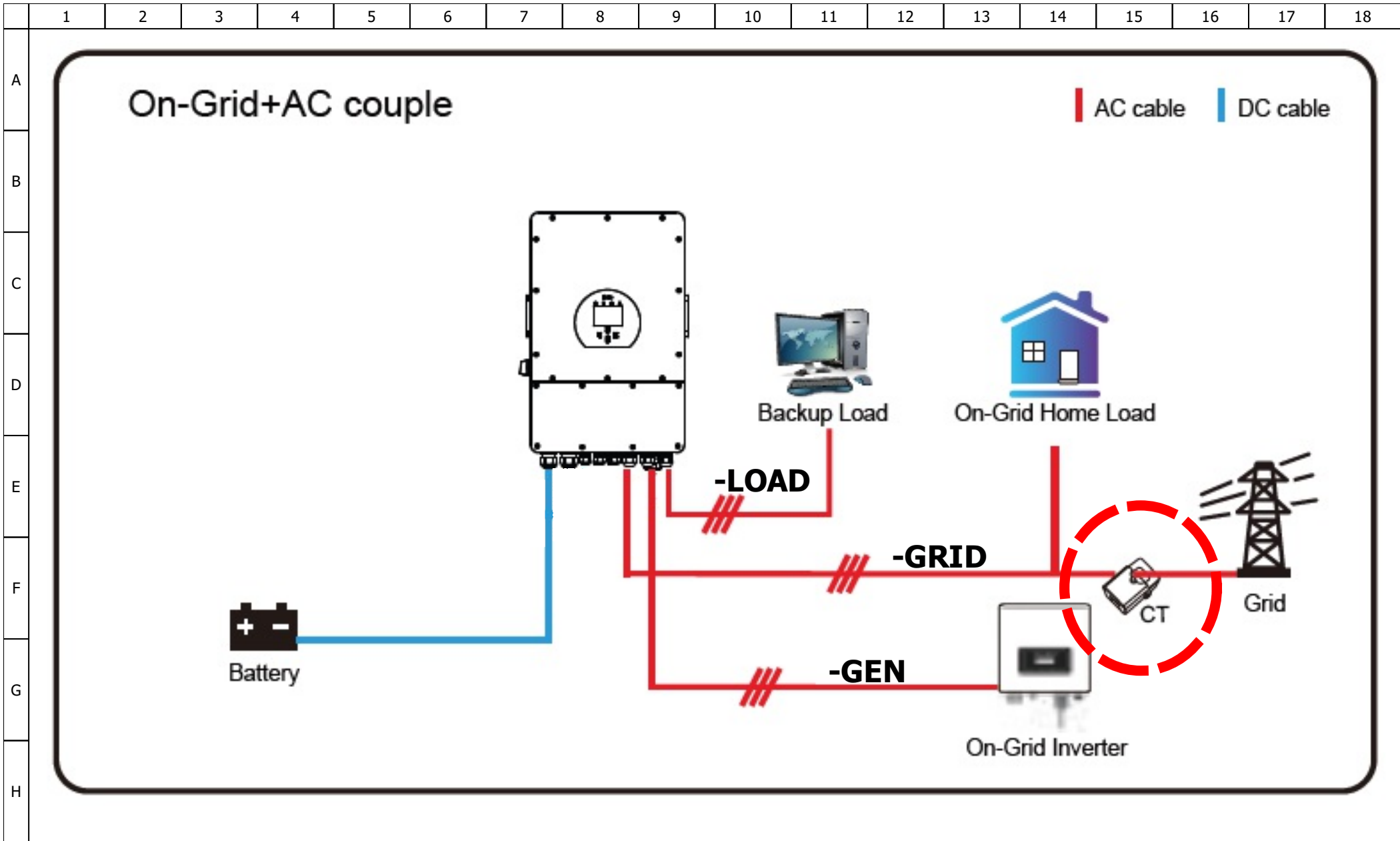

Bartosz Chorowiec: E1/712/17258/22

Maciej Wieczorek: D/681/1221/2020

Breeze Energies Sp. z o.o.

Date: 19/01/2024

2023/08/002/Z/S

ul. Kolejowa 44 05-092 Łomianki POLAND

dokumentacja

techniczna

Folio: 6/6